

SMRV063..(IEC)

输入接口 / Input adapters

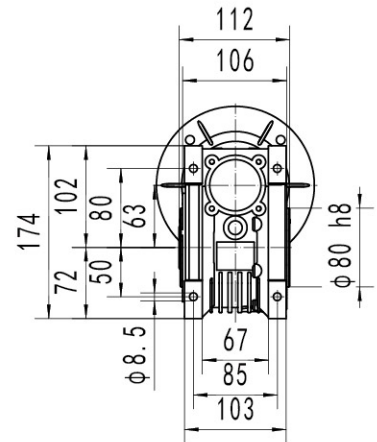

蜗杆输出轴 / Worm output shaft

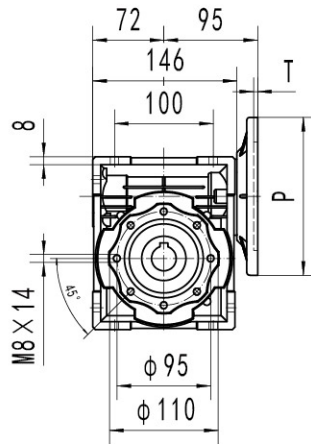
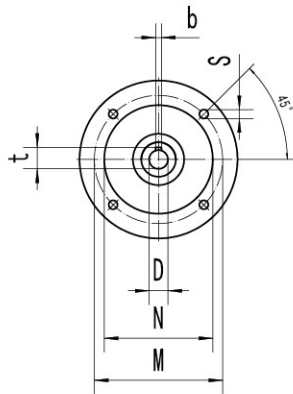
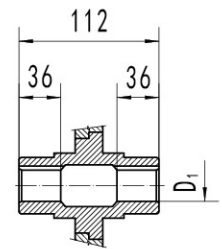
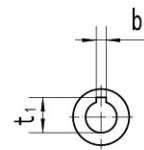
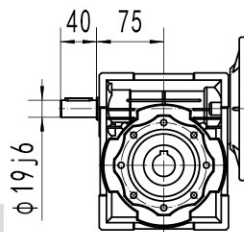
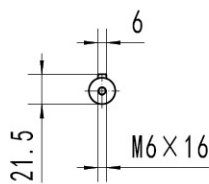

输出法兰 / Output flange

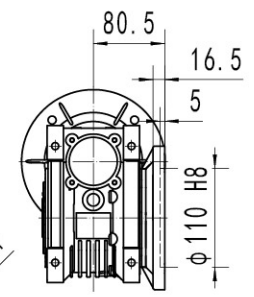
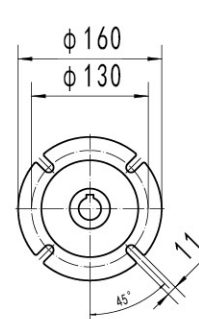
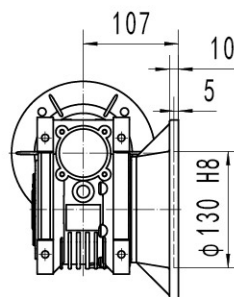
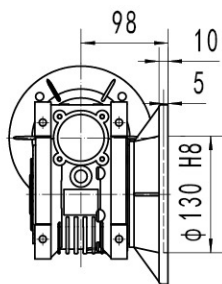
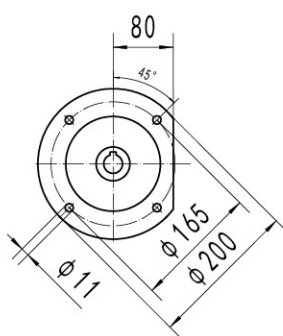
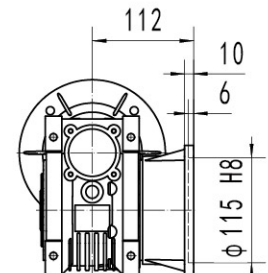
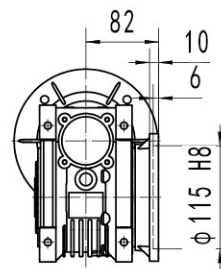
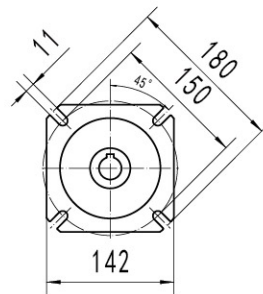

IEC	D _{ES}	b	t	P	M	N	S	T	D _{H8}	b ₁	t ₁
71B5	14	5	16.3	160	130	110	9	4	25	8	28.3
71B14	14	5	16.3	105	85	70	7	4	28*	8*	31.3
80B5	19	6	21.8	200	165	130	11	4	*非标产品, 订单时请说明 *Only on request		
80B14	19	6	21.8	120	100	80	7	4			
90B5	24	8	27.3	200	165	130	11	4			
90B14	24	8	27.3	140	115	95	9	4			

重量 (不包括马达) ≈ 6.2 kg
Weight without motor ≈ 6.2 kg