

SMRV030..(IEC)

输入接口 / Input adapters

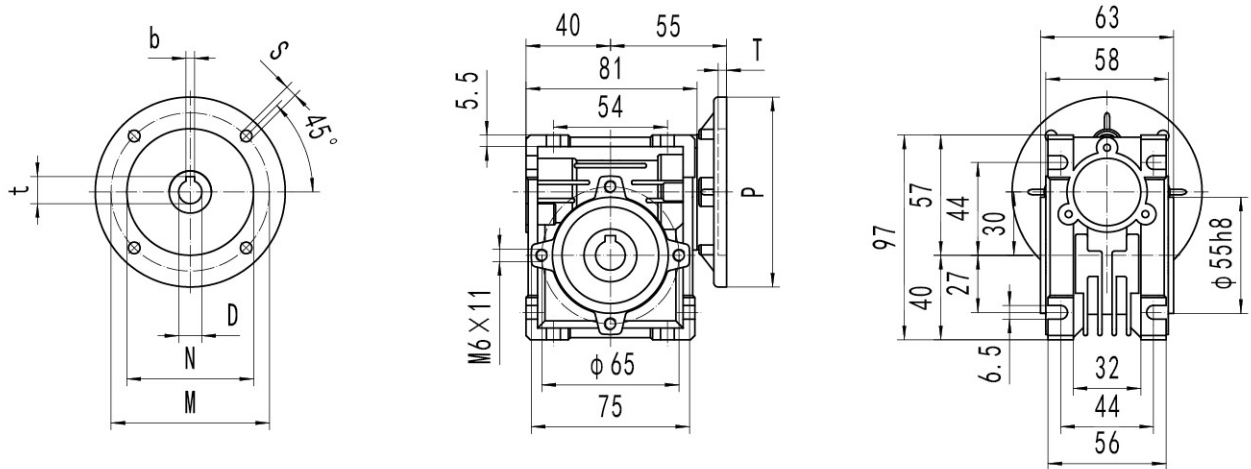

蜗杆输出轴 / Worm output shaft

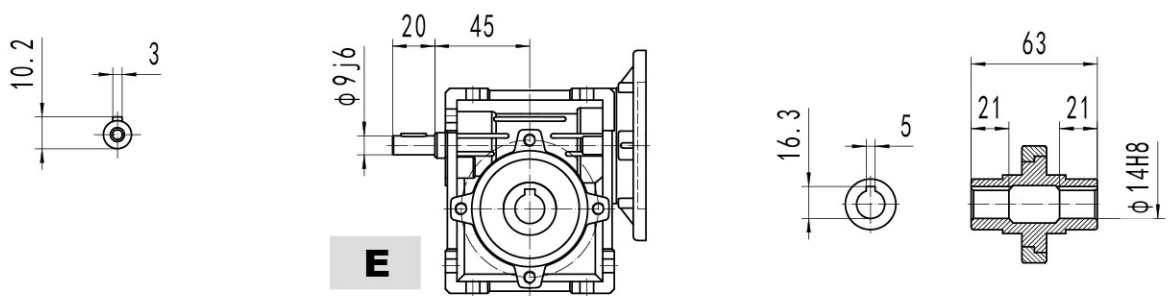

输出法兰 / Output flange

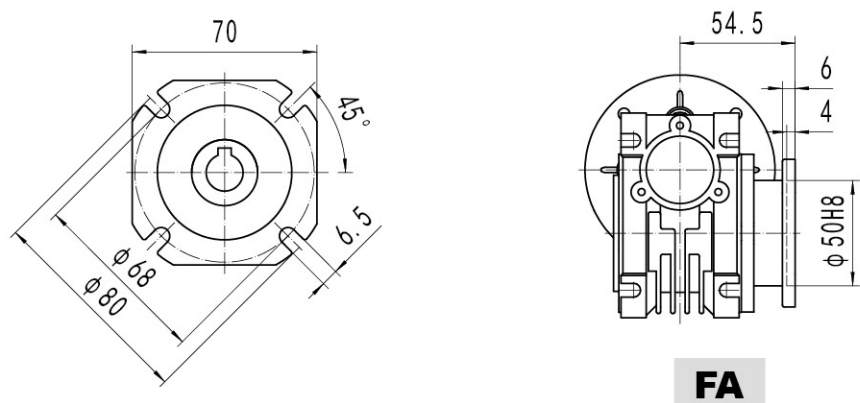

PAM IEC	D_{E8}	b	t	P	M	N	S	T
63B5	11	4	12.8	140	115	95	9.0	4
63B14	11	4	12.8	90	75	60	5.5	4
56B5	9	3	10.4	120	100	80	7.0	4
56B14	9	3	10.4	80	65	50	5.5	4

重量 (不包括马达) ≈ 1.2 kg
Weight without motor ≈ 1.2 kg